

# Biostat Water

## Dirty water Treatment Plant

Models DWPOZ20 - DWPOZ300



### Technical Information

# DWP Series Technical Bulletin

## DIRTY WATER PLANT – BACSTOP TST- OZONE - FLOCCULATION

### DWP Series Applications

The Dirty Water Plants (DWP) comprise of models 20lpm – 300lpm treatment water flow rate. Designed as a water disinfection unit for use with water containing upper limit turbidity of approximately 100 NTU\*. The treatment system combines flocculation, ozone disinfection, tetrasilver oxide (TST) for residual antibacterial/bacteriostatic function, sedimentary and activated carbon filtration. Flocculation of contaminants through addition of rapid action food grade flocculent to the system flocculation vessel, electrically generated ozone, erosion through agitation of TST balls in the water, specifically sized sedimentary filters and Inline solid block activated carbon filters (SBAC) combine to remove sedimentary contaminants, kill bacteria and other pathogens, and remove some pesticides from the treated water. Ozone and/or TST do not produce any taste or odour in the water. Activated carbon filters absorb organic compounds and can remove them from the water. These systems can remove volatile organic compounds, some pesticides, radon gas, hydrogen sulphide and mercury. The sedimentary filters remove sand and other particulate material.

\* Not for sewage or waste water

### DWP Series Components

#### Biostat Cone Bottom Flocculation Vessel

DWP systems are equipped with an integrated flocculation vessel. The plant employs a batch treatment method. Treatment by flocculation of contaminated water before disinfection provides for more effective disinfection. Flocculation serves to remove a whole range of undesirable characteristics from the water. DWP plumbing allows for recirculation of water through diversionary valves, that exclude the raw water flow from the filters, while allowing the raw water exposure to ozone. Ozone acts on water contaminants in a way that is beneficial to subsequent flocculation of the treated (ozonated) water.

#### BacStop TST Dispenser

The BacStop TST technology is a method of treating water to kill bacteria and prevent the growth/re-growth of microbes harmful to humans and animals. Using metal ions, principally nano concentrations of polyvalent silver oxide. TST is released into the water by erosion of a solid balls made from silver oxide (TST). The balls are contained and dispensed from within a special inline dispenser. The system takes advantage of the oligodynamic effect provided by the addition of silver to water.

#### Sedimentary Filter

All machines have a cartridge filter system located after the BacStop dispenser. The filters are nominally rated at 1-10 micron (depending upon conditions), all particles larger than the specific sized filter will be removed from the inlet stream. The filter system is meant to remove large particles, which could impact upon the disinfection capabilities of the machine. The number of filter housings varies with the size of machine. Typically, other forms of filtration may precede the cartridge pre-filters.

#### Activated Carbon Filter

All machines utilize cartridge activated carbon (AC) filtration. AC is most effective in removing organic contaminants from water. Organic substances are composed of two basic elements, carbon and hydrogen. Because organic chemicals are often responsible for taste, odour, and colour problems, AC filtration can generally be used to improve aesthetically objectionable water. Similar to other types of water treatment, AC filtration is effective for some contaminants and not effective for others. AC filtration **does not** remove microbes, sodium, nitrates, fluoride, and hardness. Lead and other heavy metals are removed only by a very specific type of AC filter. The consumer should assume that the AC filter is not effective in removing them. Refer to the other available BWT information in the treatment of systems that do remove the contaminants listed above.

#### Ozone Generator

Ozone used as an alternative to chlorine for disinfection, not only reduces the formation of THMs and HAA, but is also effective as a disinfectant for the control of cryptosporidium, giardia and viruses. Ozonation has also been found to improve the taste, odour and colour of water. Ozone is an extremely strong oxidizing agent. In fact, ozone is so reactive to various water contaminants that it generally does not survive very long in the treatment process. Ozone reacts with natural organics in the water supply and forms lower molecular weight organic by-products that tend to be biodegradable.

# DWP Series Technical Bulletin

## DIRTY WATER PLANT – BACSTOP TST- OZONE - FLOCCULATION

### Pumps

DWP series machines are equipped standard with Grundfos Centrifugal pumps (Other pumps types are optional). The pumps are specifically specified to deliver constant high-pressure flow ideal for water disinfection systems operation.

### Pressure Gauges

DWP series machines include stainless steel, glycerin-filled pressure gauges mounted into various locations in the machine's piping to yield pre-filter and post-filter pressure readings. The machines typically operate at a pre-filter pressure of 100 – 300 kPa with a 20 – 40 kPa pressure drop across the plant. Depends upon model and/or condition of filter element.

## DWP Series Specifications

### Water flow requirements

The machine flow specifications listed below are based on a feed water temperature of 20°C.

Model	Treatment Flow Rate (L/min)	Working Pressure (KPa)	Motor (kW)	Self Prime Max (M)
DWP20	20	240	0.37	2-3
DWP50	50	240	0.75	2-3
DWP100	100	300	1.00	2-3
DWP200	200	300	2.00	2-3
DWP300	300	300	2.50	2-3

\* Flow rates can vary ±5%.

### Flocculation / Storage Vessels

Model	Vessel Capacity (L)	Height (mm)	Width (mm)	Lid Size (mm)
DWP20	100	700	530	455
DWP50	200	1185	530	455
DWP100	500	985	1200	455
DWP200	800	1265	1200	455
DWP300	1200	1620	1200	455

### Feed water Requirements

Temperature	Minimum: 2°C	Nominal: 4 - 40°C	Maximum: 40°C
Inlet Pressure	Minimum: Flooded suction		Maximum: Flooded suction
Turbidity	100 NTU		
Operating pH	4 - 9		
Manganese	< 0.10 ppm		
Iron	< 5.0 ppm		

# DWP Series Technical Bulletin

## DIRTY WATER PLANT – BACSTOP TST- OZONE - FLOCCULATION

### DWP Series Disinfection & Filtration Specifications

#### Ozone

Model	Ozone Rate (g/Hr)	Minimum Air Flow (L/min)	Power 220-240VAC (Amps)
DWP20	0.30	3.5	10
DWP50	0.30	5.0	10
DWP100	1.00	6.0	10
DWP200	2.00	8.0	10
DWP300	4.00	12.0	10

#### BacStop TST

Model	TST Residual (Max mg/L)	Minimum Water Flow (L/min) $\pm 5\%$	TST Ball Qty. 5g x 16mm
DWP20	<0.01	20	4
DWP50	<0.01	50	10
DWP100	<0.01	100	20
DWP200	<0.01	200	40
DWP300	<0.01	300	60

#### Sediment filtration

Model	Maximum Flow Rate (L/min)	Filter Surface area (M <sup>2</sup> )	Micron rating ( $\mu\text{M}$ )
DWP20	20	1	1-5
DWP50	50	2.3	1-5
DWP100	100	4.6	1-5
DWP200	200	4.6	1-5
DWP300	300	6.90	1-5

# DWP Series Technical Bulletin

## DIRTY WATER PLANT – BACSTOP TST- OZONE - FLOCCULATION

### Activated Carbon

Model	Maximum Flow Rate (L/min)	Filter Volume (L) Area (M <sup>2</sup> )	Micron rating (µM)
DWP20	20	1M	1-10
DWP50	50	2M	1-10
DWP100	100	12L	1-10
DWP200	200	12L	1-10
DWP300	300	18L*	1-10

\* Optional 24L

### Environmental Requirements

Ambient Temperature: 4 – 40°C

**CAUTION:** This machine must not be allowed to freeze. Irreparable harm to various components will occur.

**NOTE:** This machine is designed for weather protected operation only.

**NOTE:** If this unit is operating in a humid environment, the user/operator should recognize that moisture in the air will shorten the frequency for when the dielectrics in the ozonation unit should be service and/or replaced

### Flow Description

Water for treatment is placed into the system cone bottom vessel. The centrifugal pump boosts the pressure of the feed water to the BacStop Dispenser and filter array, and by valve diversion through the ozone injection venturi only. Water from either route is returned to the flocculation vessel or to discharge. Flocculent is added to the vessel. When the flocculent has settled to a point below the booster pump inlet the diversion valve is switch to course water to flow through the TST and filter array, before discharging for use. Line pressure is measured between the pump discharge and the inlet of the BacStop housing. This measurement is the primary pressure. The feed water passes through two-round cartridge filter housings. These housing(s) are filled with replaceable cartridge filters, which remove bulk suspended solids.

The pressure is measured before and after the cartridge filter housing(s). These readings are the pre and post- filter pressures, displayed by the gauges on the piping before and after the filter housing(s). Filtered water flows to the inlet of the second filter housing. This housing is filled with activated carbon enclosed within a refillable media cartridge. Filtered water exiting the filter array will pass through a venturi. Ozone is drawn into the main water flow through the venturi while the system is on. When the DWP is turned ON, by means of the valve opening, allowing reduced water pressure to turn on the pump and ozonator. When the DWP is turned OFF, by means of closing the valve, the pressure caused by the restricted flow will turn the pump and ozonator off. The venturi is installed post the on/off valve. The location prevents pressurized water flowing back into the ozonator while in the off position.

# DWP Series Technical Bulletin

## DIRTY WATER PLANT – BACSTOP TST- OZONE - FLOCCULATION

Water is discharged from the system post the venturi and mixer tube. **CAUTION** No restriction should be applied to the discharge outlet. To do so will affect the performance of the ozone venturi and place pressurized water against the venturi ozone inlet. These factors can prevent the injection of ozone and may cause destruction of the ozonator by the influx of water into the ozonator dielectrics. The drain valve at the base of the Flocculation vessel serves to drain sludge etc. from the vessel after the vessel has been pumped low, and before the vessel is filled for next treatment.

### DWP20 Water Treatment Plant

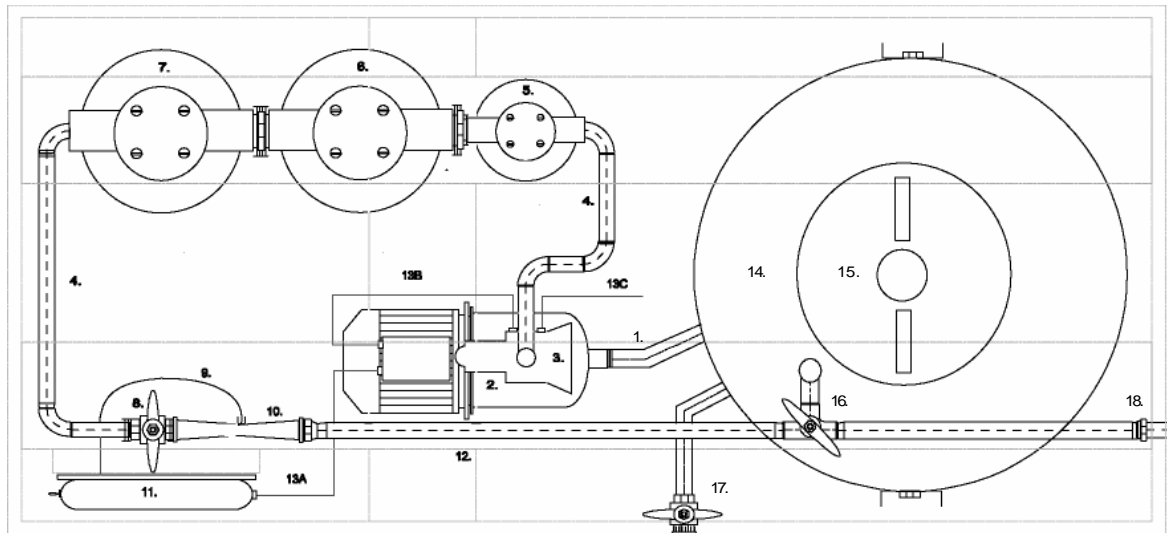

### Dirty Water Plant (DWP20) Index

1. Water pump inlet
2. Water pump
3. System pressure switch
4. Plumbing
5. Bacstop TST Dispenser
6. Sedimentary filter
7. Activated carbon filter
8. Isolation valve
9. Ozone injection tube
10. Ozone injection venturi
11. Ozonator
12. Ozone mixer tube
13. Electrical
14. Flocculation vessel
15. Flocculation vessel lid
16. Flow diversion valve
17. Flocculation vessel drain valve
18. Treated water output